

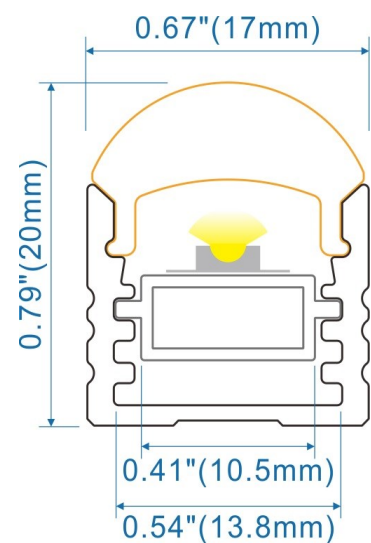

MULTI BEAM PROFILE

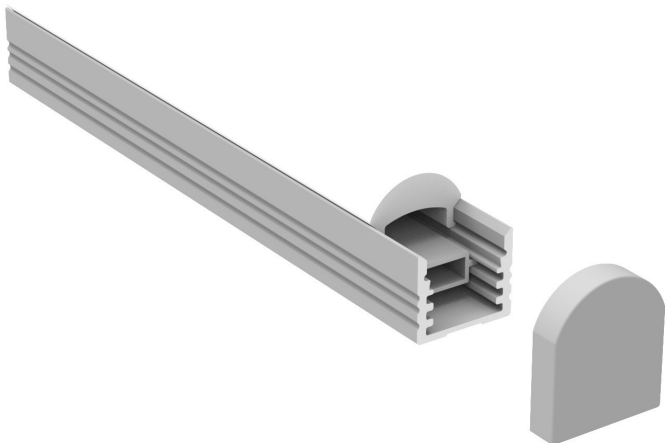

- XD1720 Multi Beam LED Profile Surface Mounted
- 6063 anodised aluminium LED profile
- 17x20x2000mm
- Clear lens diffuser with multiple beam angle options
- Sold separately in lengths of 2000mm with 3 x clips and 2 x end cap
- Available in a range of LED strip options

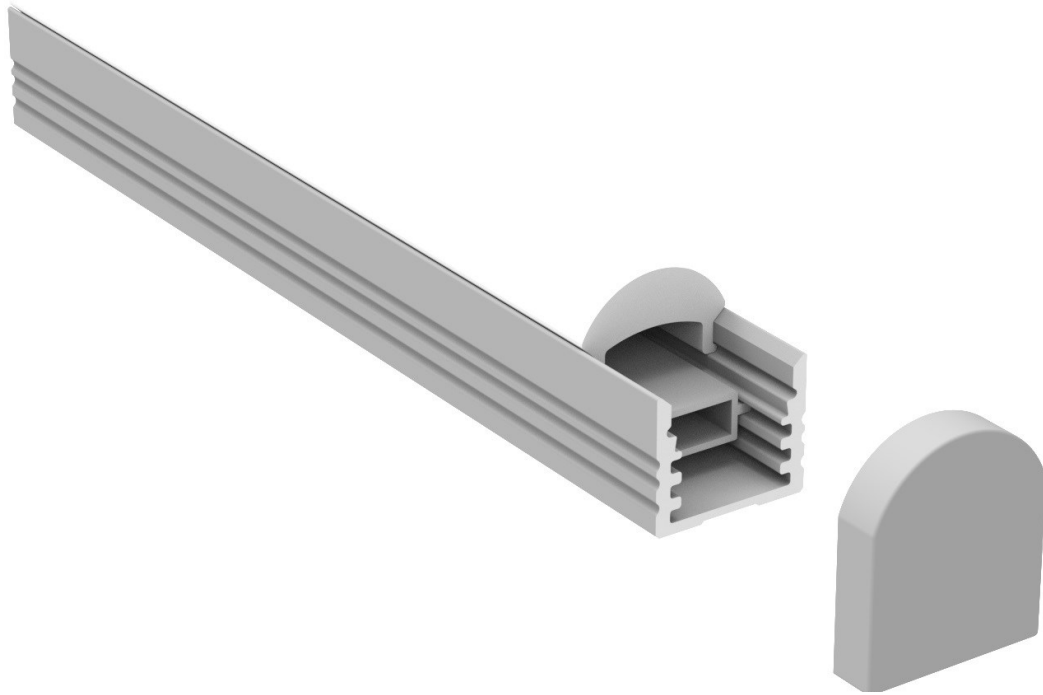

The Lightrail XD1720 Multi Beam LED Profile enables you to choose a beam angle by simply changing the position of the LED strip as shown. Perfect for applications such as wall washing or anywhere a tighter beam angle is required

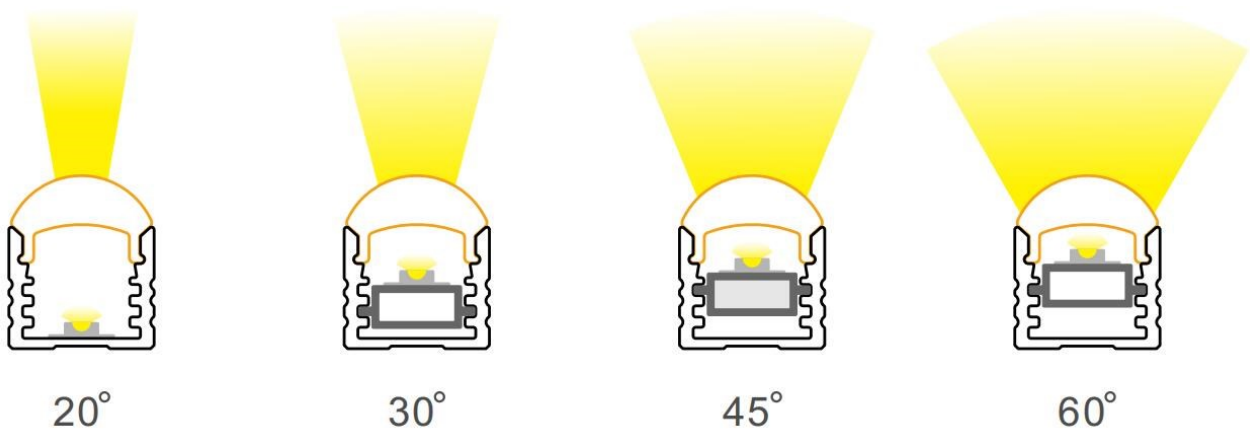

Aluminum 6063-T5

Component	Wt. %	Component	Wt. %	Component	Wt. %
Al	Max 97.5	Mg	0.45 - 0.9	Si	0.2 - 0.6
Cr	Max 0.1	Mn	Max 0.1	Ti	Max 0.1
Cu	Max 0.1	Other, each	Max 0.05	Zn	Max 0.1
Fe	Max 0.35	Other, total	Max 0.15		

Physical Properties	Metric	English	Comments
Density	2.7 g/cc	0.0975 lb/in ³	AA; Typical

Mechanical Properties

Hardness, Brinell	60	60	AA; Typical; 500 g load; 10 mm ball
Ultimate Tensile Strength	186 MPa	27000 psi	AA; Typical
Tensile Yield Strength	145 MPa	21000 psi	AA; Typical
Elongation at Break	12 %	12 %	AA; Typical; 1/16 in. (1.6 mm) Thickness
Modulus of Elasticity	68.9 GPa	10000 ksi	AA; Typical; Average of tension and compression. Compression modulus is about 2% greater than tensile modulus.
Poisson's Ratio	0.33	0.33	
Fatigue Strength	68.9 MPa	10000 psi	AA; 500,000,000 cycles completely reversed stress; RR Moore machine/specimen
Shear Modulus	25.8 GPa	3740 ksi	
Shear Strength	117 MPa	17000 psi	AA; Typical

Electrical Properties

Electrical Resistivity	3.16e-006 ohm-cm	3.49e-006 ohm-cm	AA; Typical at 68°F
------------------------	----------------------------------	------------------	---------------------

Thermal Properties

CTE, linear 68°F	23.4 μm/m-°C	13 μin/in-°F	AA; Typical; Average over 68-212°F range.
CTE, linear 250°C	25.6 μm/m-°C	14.2 μin/in-°F	Average over the range 20-300°C
Heat Capacity	0.9 J/g-°C	0.215 BTU/lb-°F	
Thermal Conductivity	209 W/m-K	1450 BTU-in/hr-ft ² -°F	AA; Typical at 77°F
Melting Point	616 - 654 °C	1140 - 1210 °F	AA; Typical range based on typical composition for wrought products 1/4 inch thickness or greater
Solidus	616 °C	1140 °F	AA; Typical
Liquidus	654 °C	1210 °F	AA; Typical

Processing Properties

Annealing Temperature	413 °C	775 °F	hold at temperature for 2 to 3 hr; cool at 50 °F per hour from 775 to 500 °F
Solution Temperature	521 °C	970 °F	
Aging Temperature	182 °C	360 °F	hold at temperature for 1 hr

