

POWER SOURCE



**5 YEAR
WARRANTY**

200W

Phase Cut Dimmable LED Driver with PWM Output

Features of the PDV-200 Series:



Constant
Voltage PWM
Output



IP66 Design
For Outdoor
Installation



AC Input Range:
200-240VAC



Cooling by
Free Air
Convection



Protections:
• Short Circuit
• Over Load
• Over Temperature



Factory
Fitted Flex
and Plug



Class I
Power Supply



Compatible
with Most
Leading and
Trailing Edge
Dimmers



CE    SELV

Model		PDV-200-12	PDV-200-24
Output	DC voltage	12V	24V
	Voltage tolerance	±0.5V (see Note 2.)	
	Rated current	16.6A	8.3A
	Rated power	200W	
Input	Voltage range	200-240VAC	
	Frequency range	47~63HZ	
	Power factor	PF ≥ 0.97/200VAC PF ≥ 0.97/230VAC PF ≥ 0.97/240VAC (Full loading)	
	Full load efficiency (Typ.)	86%	87%
	AC current (Max.)	1.4A	1.4A
	Leakage current	<0.50mA	
	Inrush current	Cold Start 55A (twidth = 220us measured at 50% Ipeak) at 230 VAC	
	MAX. No. of drivers on 16A Circuit breaker	4 units (circuit breaker of type B) / 6 units (circuit breaker of type C) at 230VAC	
Protection	Short circuit	Shut down o/p voltage, re-power on to recover after fault condition is removed	
	Over loading (Note 4.)	≤120% constant current limiting, auto-recovery	
	Over temperature	≤100°C± 10°C shut down o/p voltage, re-power on to recover	
Environment	Working TEMP.	-40~+60°C (refer to de-rating curve)	
	Working humidity	20~95%RH, non-condensing	
	Storage TEMP, humidity	-40~+80°C, 10-95%RH	
	TEMP. coefficient	±0.03%/°C (0~40°C)	
Safety & EMC	Vibration	10-500Hz, 2G 10min./1 cycle, period for 72min, each along X, Y, Z axes	
	Safety standards	EN61347-1 EN61347-2-13	
	Withstand voltage	I/P-O/P:3.75KVAC I/P-FG:1.88KVAC O/P-FG:0.5KVAC	
	Isolation resistance	I/P-O/P I/P-FG O/P-FG:100MΩ/500VDC/25°C/70%RH	
	EMC emissions (Note 3.)	EN55015, EN61000-3-2,3 (≥60%loading)	
Others	EMC immunity	EN61000-4-2,3,4,5,6 , 11, EN61547	
	Net. weight	1.45kg	
	Size	265*78*47mm(L*W*H)	
Notes	Packing	265*83*65mm inner box, 340*280*185mm outside carton 10PCS /CTN	
	<ol style="list-style-type: none"> All parameters NOT specially mentioned are measured at 230VAC input, rated load and 25°C of ambient temperature. Tolerance: Includes set up tolerance, line regulation and load regulation. The LED driver is considered as a component that is operated in conjunction with final equipment. EMC performance could be affected by the complete installation. Original equipment manufacturers may need to conduct additional EMC testing and certification on the final equipment. Loading range from 10% to 100%. Specifications are subject to change without prior notice. Contact your supplier to confirm any critical parameters. 		

Dimming Operation

- Dimming is with installing a leading edge, or trailing edge dimmer across the AC input.
- Compatible with most leading edge and trailing edge dimmers. Australian compatibility table available on request.
- It is recommended that a dimmer, with a power rating three times higher than that of the rated output of the LED driver is used.

Mechanical Specification

- Output cable type: Rubber H05RN-F 2*1.5mm²
- Connect LED to LED driver via the output cable: Red output(V+) Positive, Black output (V-) negative.
- Incorrect wiring could result in damage to the LED driver, which is not covered by the warranty.
- Contact your supplier with specific input, or output configuration requests.

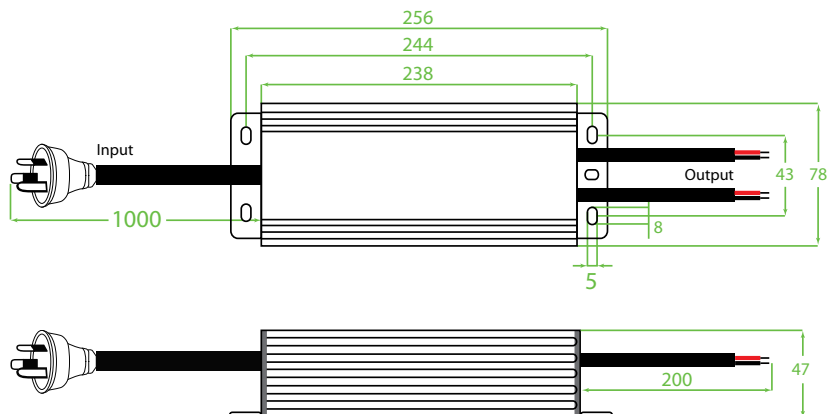

Connection Diagram

Single Driver Connection Diagram

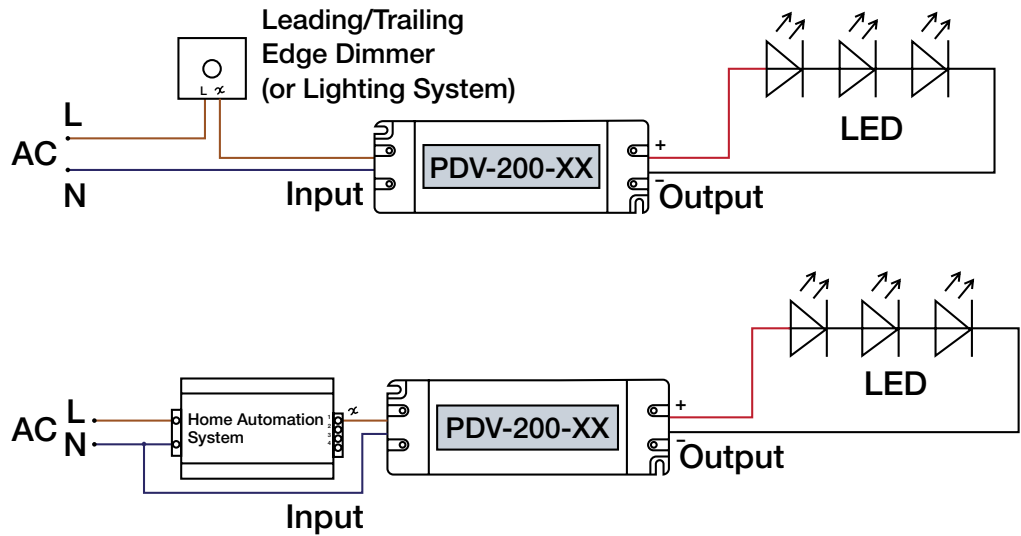

Multiple Drivers Connection Diagram

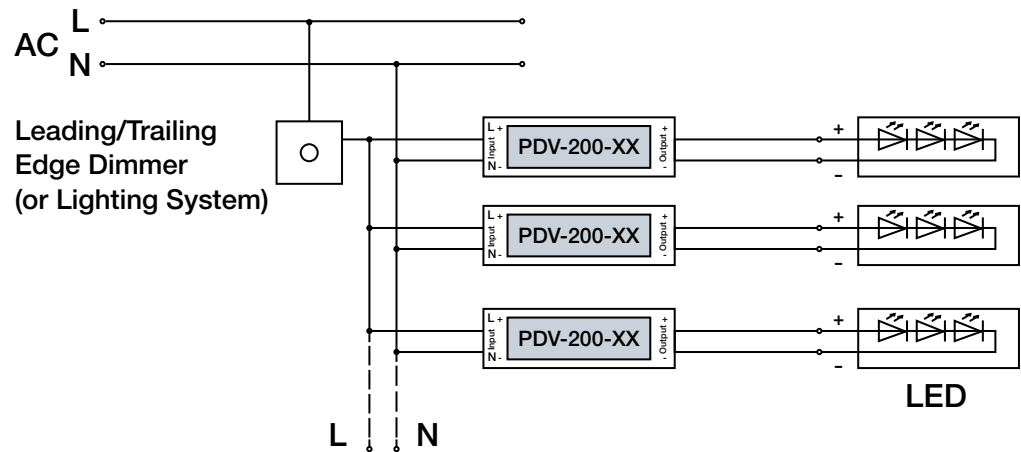

De-rating Curve

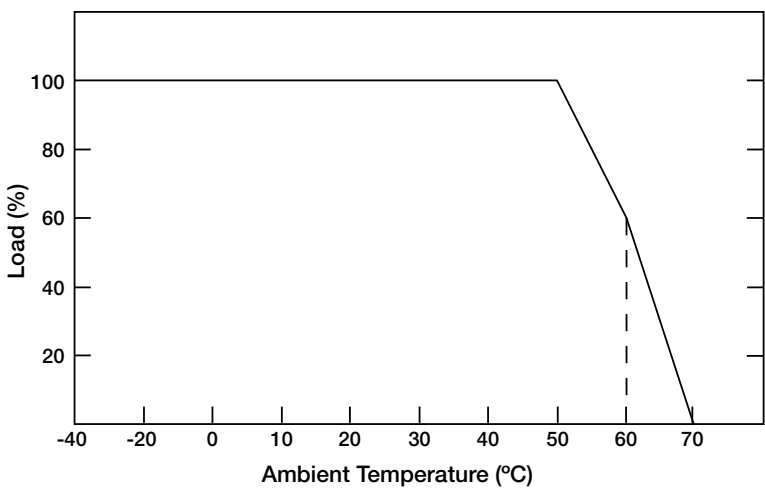

• If being used in higher ambient temperatures, ensure the load on the LED driver is de-rated in accordance with this chart. Failure to do so could lead to a premature failure, which is not covered by the warranty.



Important

- 1) This LED driver should be installed by a qualified electrician.
- 2) Please make sure the LED driver is installed with adequate ventilation around it to allow for heat dissipation.
- 3) Ensure that all wiring is correct before testing in order to avoid damage to the LED driver, or the LEDs.